

XLGUM06-D

Monture Inclinée Intérieur pour Dôme Fixe



Bracket

Application	Monture Inclinée pour Intérieur
Dimensions	Φ108 x 24.2mm / Φ4.25" x 0.95"
Poids	0.1 lb / 0.04 kg
Matériel	Plastique

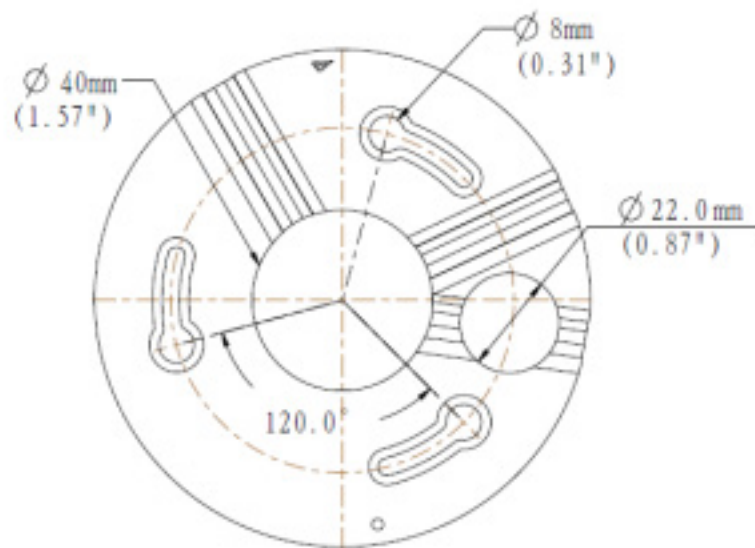
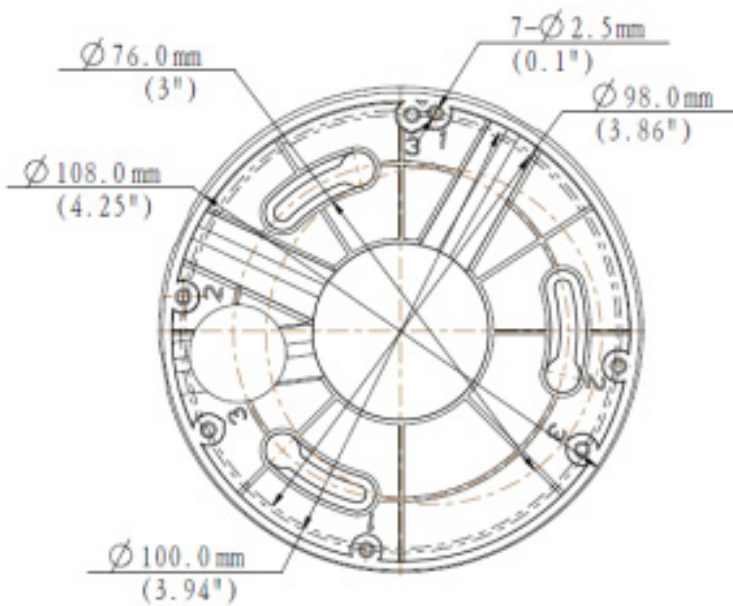
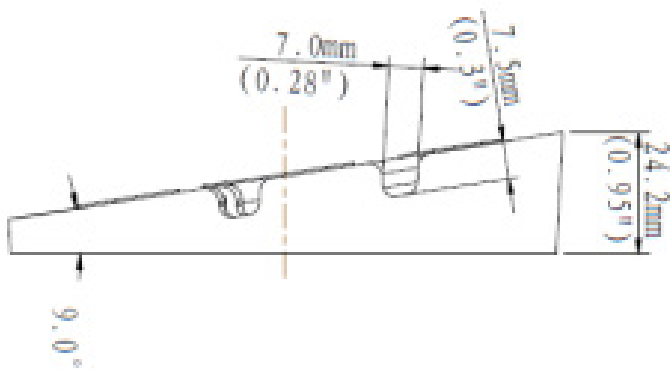

*Les dimensions et graphiques sont sujet aux changements sans préavis.